



The company started its activity in the field of machines industry since 1993. It is one of the largest factories in this field in Egypt, the company started its career by manufacturing clay brick lines, crushers, automatic cement brick lines and concrete plants.

Our clients are spread all over the Republic of businessmen and contracting companies the company has partnered with foreign and European companies to raise the efficiencies and increase the experience, as it has become the first company in Egypt to produce these products with European specifications since 2020 under the name of Pyramids.

بدأت الشركة نشاطها في مجال صناعة الآلات والمعدات منذ عام 1993، وتعد واحدة من أكبر القلاع الصناعية في هذا المجال بمصر. استهلّت الشركة مسيرتها بتصنيع خطوط إنتاج الطوب الطفلي، والكسارات، وخطوط إنتاج الطوب الأسمنتي الآلية.

تنتشر قاعدة عملائنا في جميع أنحاء الجمهورية، وتضم نخبة من رجال الأعمال وشركات المقاولات. كما عقدت الشركة شراكات مع جهات أجنبية وأوروبية لرفع الكفاءة وتعزيز الخبرات، مما جعلها الشركة الأولى في مصر التي تقدم هذه المنتجات بمواصفات أوروبية منذ عام 2020 تحت العلامة التجارية "بيramidز" (Pyramids).

+20 105 089 8929 - +20 115 318 4667

www.pyramidsmachine.com

Pyramidsteel.sales@gmail.com
info@pyramidsmachine.com

Factory: Industrial Area - El-Saf- Giza
The company's headquarters: Villa No. 5 - Street 291. El Maadi - Cairo - Egypt



BLOCK MAKING MACHINE QUOTATION



PY 5025



PY-30 FULLY AUTOMATIC BLOCK MAKING MACHINE

MAINE MACHINE

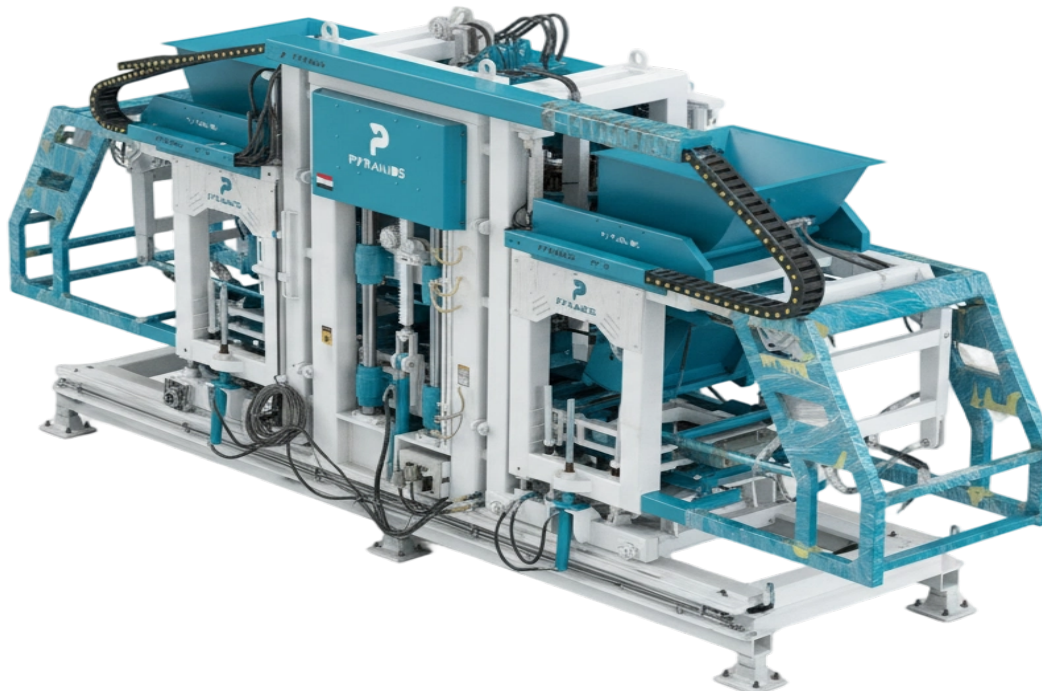

Production Capacity	:120-130 Pallet Per Hour
Hopper Capacity	: 500 dm3
Control	: Plc Automation System (siemens)
Hydraulic Oil Capacity / Brand	:500 Lt / Italian
Upper Vibration	:3 KW X 2
Lower Vibration	: 4 Kw x 4
Inner Swing System	:Yes - Hydraulic
Maximum Product Height	:30 cm
Machine Chassis Frame	:10MM Profile
System of Vibration	:Classic belt and pulley vibration
Back Dry product	: Hydraulic driver

 **+20 105 089 8929 - +20 115 318 4667**

 **www.pyramidmachine.com**

 **Pyramidsteel.sales@gmail.com**
info@pyramidmachine.com

 **Factory: Industrial Area - El-Saf- Giza**
The company's headquarters: Villa No. 5 - Street 291. El Maadi - Cairo - Egypt



VIBRATION TABLE



WORKING PRINCIPLE OF BLOCK MAKING MACHINE

They are machines that work with a hydraulic system in the pressure range of 100-130 bar. It is a machine that produces 10 pieces of 20x40x20 cm standard briquettes and 30 pieces of locked paving stones in one press. Printing pallets are needed for production. The concrete compressed in the molds is pressed on the pallets. The products produced in the same way are left to dry on printing pallets.

 +20 105 089 8929 - +20 115 318 4667

 www.pyramidmachine.com

 Pyramidsteel.sales@gmail.com
info@pyramidmachine.com

 **Factory:** Industrial Area - El-Saf- Giza
The company's headquarters: Villa No. 5 - Street 291. El Maadi - Cairo - Egypt



STACKING SYSTEM ROBOT FOR WET AND DRY PRODUCTS



Stacking layer	: 5 – 7 Row.
Cleaning Brush	: Yes
Back Dry product	: Hydraulic driver

WORKING PRINCIPLE

The system stacks pallets for wet products. Wet product driver includes brush for deburring. Pallet driver included.

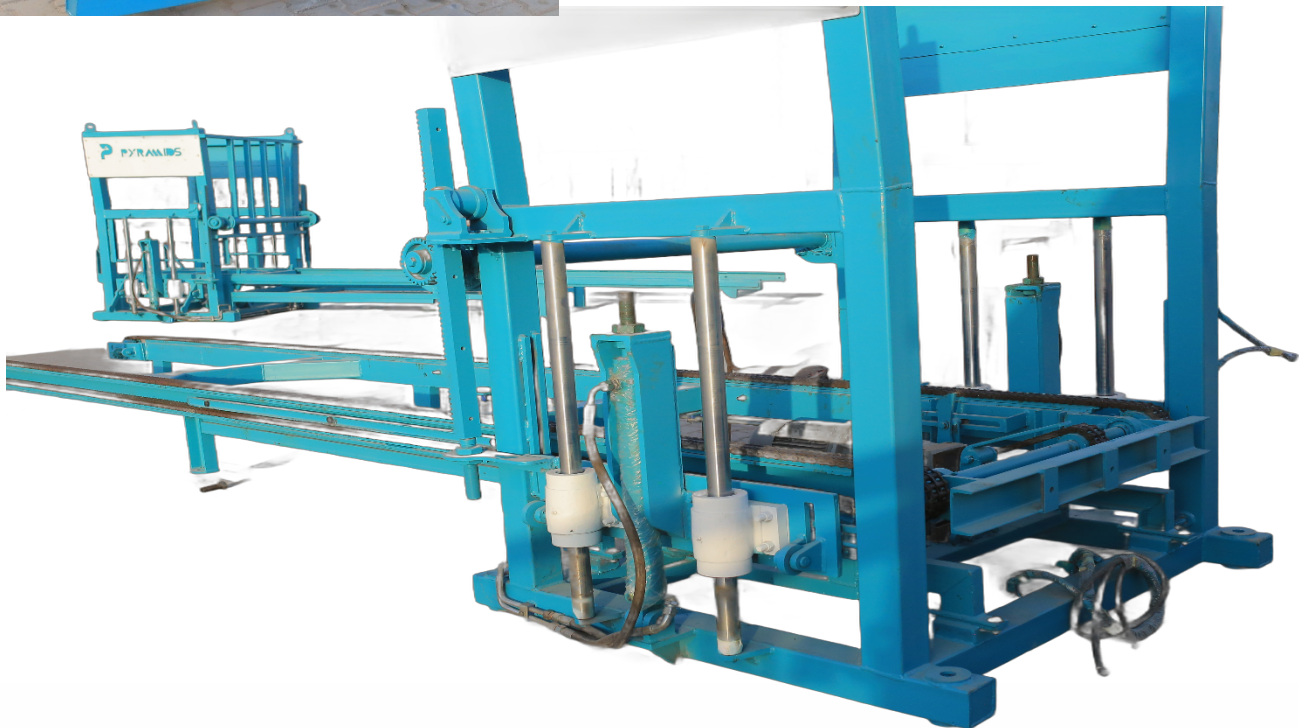

+20 105 089 8929 - +20 115 318 4667

www.pyramidmachine.com

Pyramidsteel.sales@gmail.com
info@pyramidmachine.com

Factory: Industrial Area - El-Saf- Giza
The company's headquarters: Villa No. 5 - Street 291. El Maadi - Cairo - Egypt



PLC AUTOMATION SYSTEM FOR MAIN MACHINE

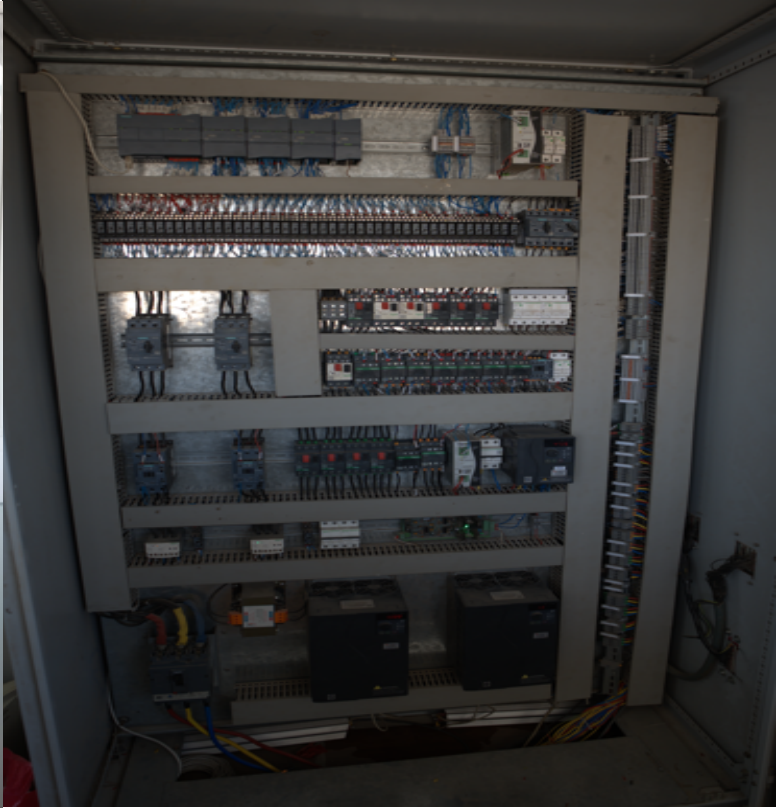

PLC BRAND	: Plc Automation System (siemens)
SCREEN	:24-inch TOUCH SCREEN

WORKING PRINCIPLE OF PLC AUTOMATION SYSTEM

The control panel provides easy-control for the machine with sensors. The automation panel allows you to store daily production. It is easy to use control panel. Also provides required timing for different types of blocks and paving stones.

+20 105 089 8929 - +20 115 318 4667

www.pyramidmachine.com

Pyramidsteel.sales@gmail.com
info@pyramidmachine.com

Factory: Industrial Area - El-Saf- Giza
The company's headquarters: Villa No. 5 - Street 291. El Maadi - Cairo - Egypt



750DCM3 DOUBLE SHAFT MIXER



750DCM3 DOUBLE SHAFT MIXER

<i>Main mixer</i>	Capacity	: 750 DCM3
	Main Body Inner Linings	: ST 52 REINFORCED PRODUCTION
	Mixer Type	: Double shaft
	Motor Power	: 18.5 Kw x 2

+20 105 089 8929 - +20 115 318 4667

www.pyramidsmachine.com

Pyramidsteel.sales@gmail.com
info@pyramidsmachine.com

Factory: Industrial Area - El-Saf- Giza
The company's headquarters: Villa No. 5 - Street 291. El Maadi - Cairo - Egypt



250 DCM3 SINGLE SHAFT MIXER



250 DCM3 SINGLE SHAFT MIXER

<i>Second Mixer</i>	Capacity	: 250 DM3
	Main Body Inner Linings	: St52 Reinforced Production
	Mixer Type	: Single shaft
	Motor Power	11 kw

+20 105 089 8929 - +20 115 318 4667

www.pyramidsmachine.com

Pyramidsteel.sales@gmail.com
info@pyramidsmachine.com

Factory: Industrial Area - El-Saf- Giza
The company's headquarters: Villa No. 5 - Street 291. El Maadi - Cairo - Egypt



AGGREGATE BUNKER 15 M3 X 3

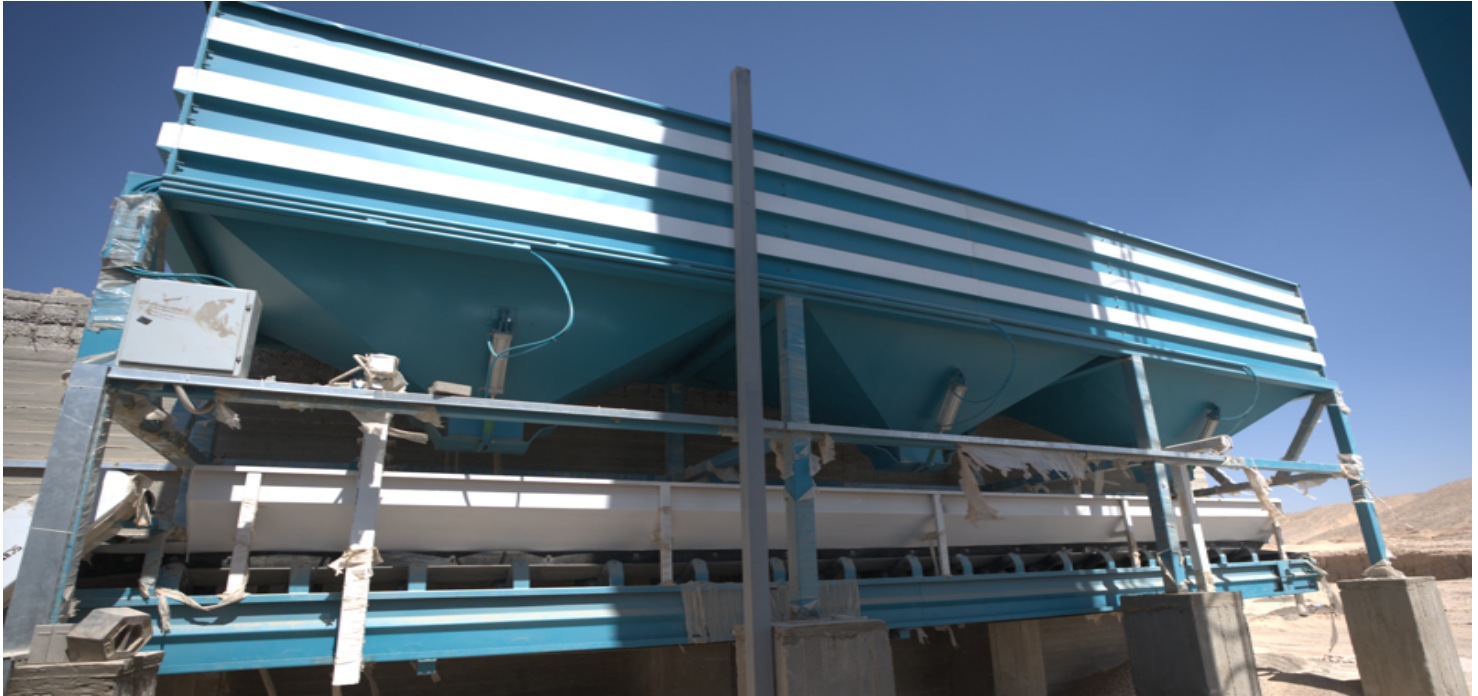

1-AGGREGATE BUNKER 15 M3 X 3

<i>Hoppers</i>	Bin Capacity	: 15m3 x3
	Band Rubber	: 4-coat linen conveyor
	Vibrator Caps	: 0,55 kw
	Weighing	: Sensitive weighing system

2- AGGREGATE WEIGHING BELT 9 MT 70 CM

<i>Weighing Band</i>	Length	: 9 mt 70CM
	Band Rubber	: 4-coat linen conveyor
	Loadcell Capacity	: 2000 Kg x 4

 **+20 105 089 8929 - +20 115 318 4667**

 **www.pyramidmachine.com**

 **Pyramidsteel.sales@gmail.com**
info@pyramidmachine.com

 **Factory: Industrial Area - El-Saf- Giza**
The company's headquarters: Villa No. 5 - Street 291. El Maadi - Cairo - Egypt



The purpose of the separation type of gravels, sand is to weigh these materials separately according to the appropriate criteria for obtaining the best quality for the required blocks or pavers. The system has 2x3 pneumatic caps and this helps to make sensitive weighing of the aggregates.

AGGREGATE BUNKER 15 M3 X 1





The weighing process is carried out by a belt process directly in the bottom section of bunker and is suspended by 4 units Weight sensors.

1-AGGREGATE BUNKER 15 M3 X 1		
<i>Hoppers</i>	Bin Capacity	: 15m3 x1
	Band Rubber	: 4-coat linen conveyor
	Vibrator Caps	: 0,55 kw
	Weighing	: Sensitive weighing system
2- AGGREGATE WEIGHING BELT 9 MT 65CM		
<i>Weighing Band</i>	Length	: 4 mt 65CM
	Band Rubber	: 4-coat linen conveyor
	Loadcell Capacity	: 2000 Kg x 4



AGGREGATE AND CONCRETE TRANSFER CONVEYOR



 +20 105 089 8929 - +20 115 318 4667

 www.pyramidmachine.com

 Pyramidsteel.sales@gmail.com
info@pyramidmachine.com

 **Factory:** Industrial Area - El-Saf- Giza
The company's headquarters: Villa No. 5 - Street 291. El Maadi - Cairo - Egypt





Conveyor Aggregate Sizes: 65 x 8.000 mm

Conveyor Concrete Sizes: 65 x 12.000 mm

Chassis Material: Bended sheet metal – 4 mm

Electric Motor: 4 kW, 1400 rpm, GAMAK Brand

Gearbox Brand: heavy duty type

Bearings: FAG or SKF Brand

Heavy duty type bearing housings are used.

Belt rubber: Quality DRP 125, No of layers: 4, Belt rubber thickness: 10 mm

Belt rubber brand: DRP

Drums: Ø270 mm, 8 mm thickness.

Both Drums are covered with rubber.

 **+20 105 089 8929 - +20 115 318 4667**

 **www.pyramidmachine.com**

 **Pyramidsteel.sales@gmail.com
info@pyramidmachine.com**

 **Factory: Industrial Area - El-Saf- Giza
The company's headquarters: Villa No. 5 - Street 291. El Maadi - Cairo - Egypt**



<u>SILO</u>	
Capacity	: 120 TONNES
Safety	: 24m2 clear area filter
Loading Pipe	: 4 inch

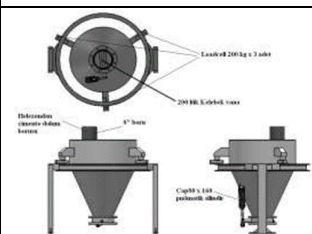

<u>CEMENT WEIGHING SYSTEM</u>		
	Capacity	: 200 Kg
	Thickness	: 4 mm
	Pneumatic and PLC Control System	



MOLDS

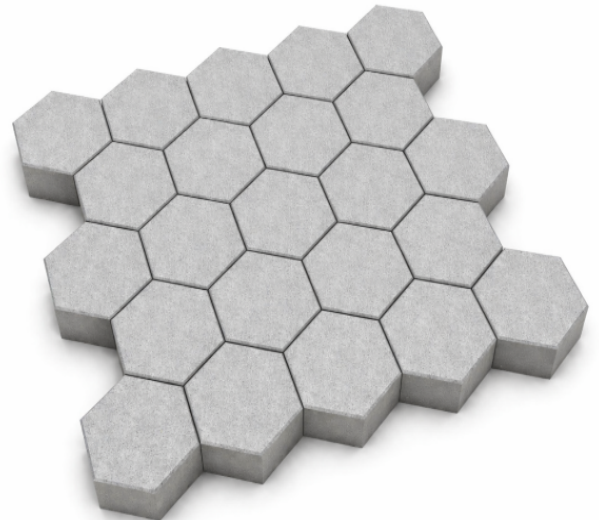
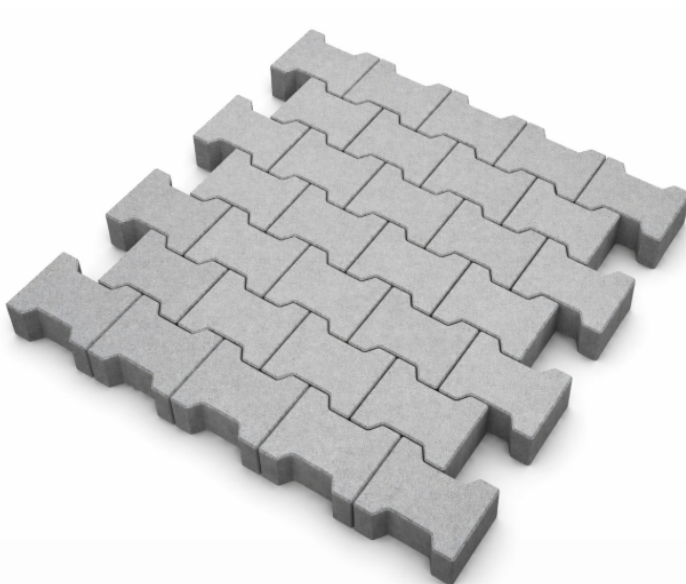
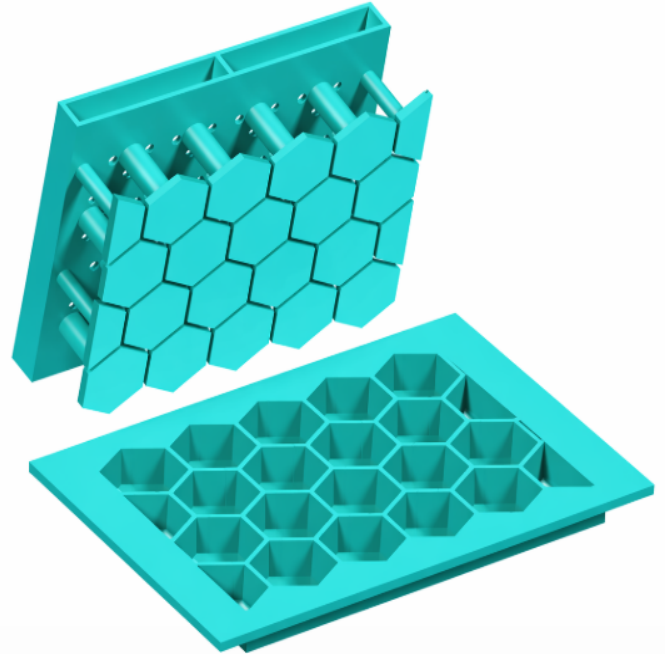
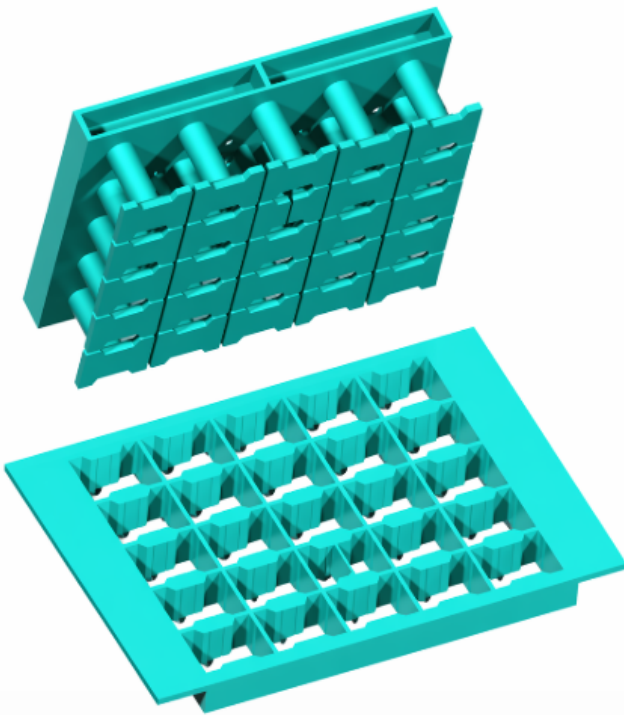

FINAL PROUDECT

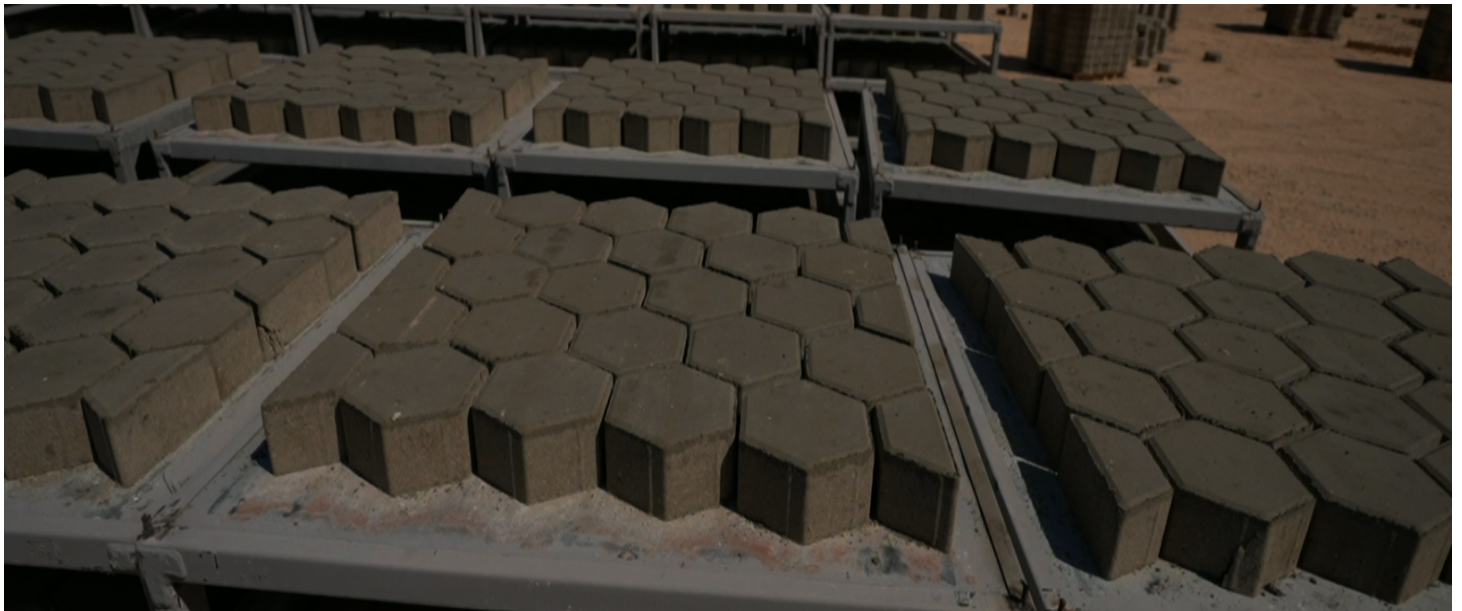

Factory Layout

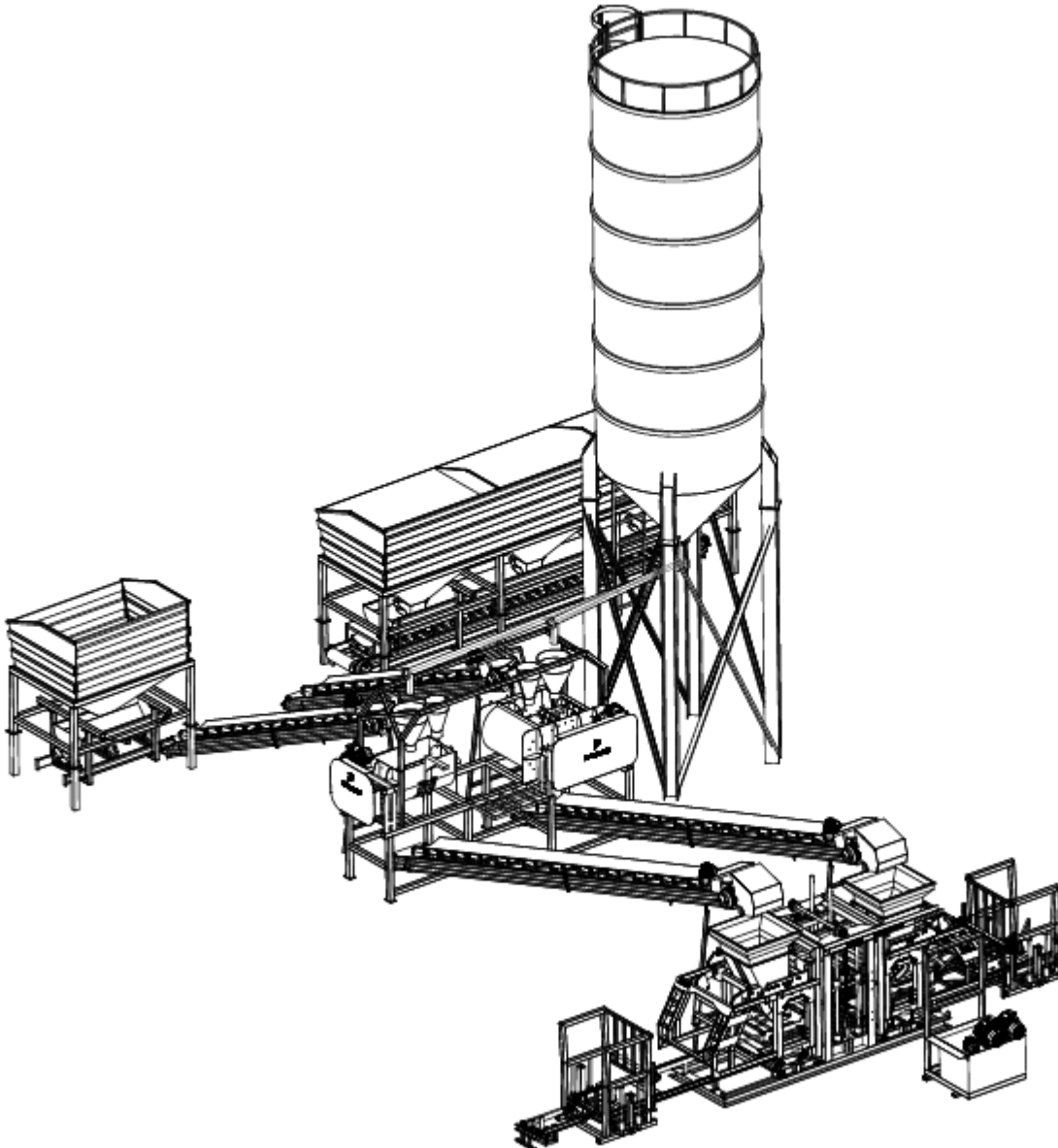

 +20 105 089 8929 - +20 115 318 4667

 www.pyramidmachine.com  Pyramidsteel.sales@gmail.com
info@pyramidmachine.com

 **Factory:** Industrial Area - El-Saf- Giza
The company's headquarters: Villa No. 5 - Street 291. El Maadi - Cairo - Egypt



Factory Layout

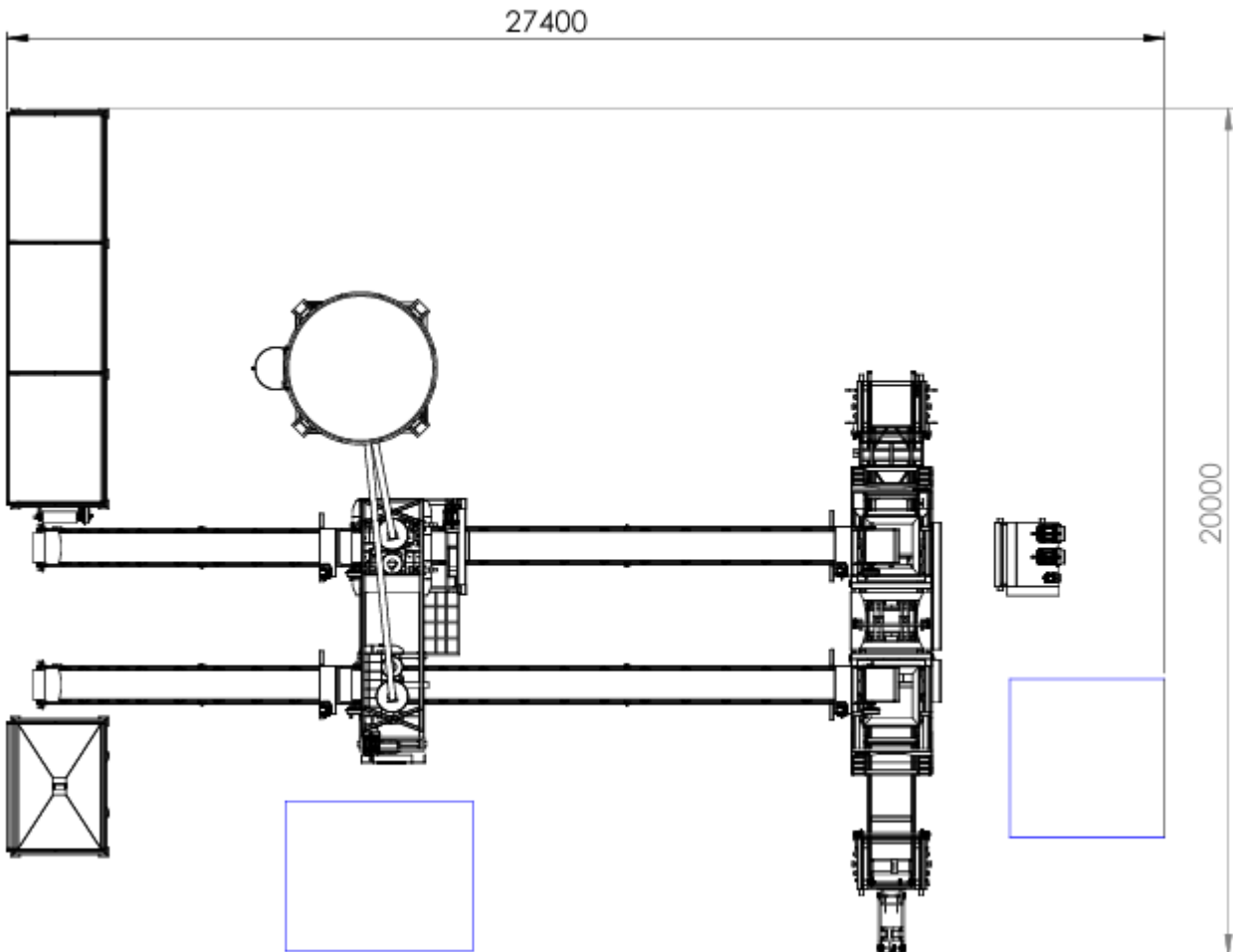

العرض المالى

ماكينه البلوك والانترولوك

الكمية	المنتج
قطعة	ماكينة انترولوك وبلوك وبلدورة
قطعة	سير ادخال الباليئات
قطعة	ربوت تفريغ الباليئات
قطعة	وحدة التحكم الهيدروليكية للباليتات
قطعة	وحدة التحكم الهيدروليكية للماكينة
قطعة	لوحة التحكم الكهربائية PLC نظام التحكم
قطعتين	قوالب حسب اختيار العميل

محطة خرسانة للماكينة

الكمية	المنتج
1 قطعة	خلاطة مزدوجة مجهزة بمنصة كاملة سعة 750 دسم3
1 قطعة	خلاطة سعة 250 دسم3
2 قطعة	سير نقل الرمل
2 قطعة	سير نقل المونة و الخامات
1 قطعة	فيدر تجميع المواد الخام الخشنه (3×15 متر)
1 قطعة	سير وزن الخامات الخشنه
1 قطعة	فيدر تجميع المواد الخام الناعمه (1×15 متر)
1 قطعة	سير وزن الخامات الناعمه
2 قطعة	ميزان الاسمنت
2 قطعة	نظام وزن المياة
2 قطعة	بريمة لنقل الاسمنت
1 قطعة	سايلو اسمنت سعة 120 طن
1 قطعة	لوحة التحكم الكهربائية PLC نظام التحكم
1 قطعة	وحدة وزن أوكسيد الألوان
السعر الاجمالي للمكينة غير شامل الضريبة والشحن	



الطاقة الانتاجية لماكنة PY 5025

فى عدد 10 ساعات الوردية:

انتاج الوردية	عدد ساعات الوردية	الكبسة	المنتج	م
104,000	10 ساعات	52	مصمت 12*6*25	1
130.000	10 ساعات	64	مصمت 12*6*20	2
16000	10 ساعات	10	بلوك 20	3
30000	10 ساعات	20	بلوك 10	
900 متر	10 ساعات	40	باركيه	
800 متر	10 ساعات	25	حرف أي	
800 متر	10 ساعات	20	انترلوك سداسي	

